

FRYGRB

N.º	Código	Denominación	70	100
1	47250070	Amazon	1	1
2	16000100	Quemador Tubular	2	2
3	14002140	Termopar 8x1	2	3
4	27250015	Omega Soporte Inyector	2	2
5	16000240	Soporte Inyector Barbacoa	1	1
6	15000420	Inyector GLP 0,85	2	4
7	15000400	Inyector GLP 0.93	2	2
8	27250010	Omega Bujia Frytop	1	2
9	47810020	Conj. quemador pescado	2	4
10	12100230	Codo 1/4 Macho/Hembra	2	4
11	12050050	Tuerca M4	8	8
12	12050080	Tuerca M8	6	6
13	12006200	Tornillo M6x20	12	12
14	14002410	Bujia Quemador	1	2
15	12204310	Tubo aluminio Barbacoa	1	2
16	12100320	T de 1/4 mmm	1	2
17	12204390	Tubo aluminio FryTop T	2	4
18	12204380	Tubo aluminio FryTop	1	1
19	14002600	Piezo electrico	1	2
20	37250135	Peto Barbacoa ensamblado	1	1
21	12502140	Parrilla Interior Barbacoa	1	1
22	27240160	Bandeja recoge grasas	1	1
23	12502046	Parrilla Acanalado Barbacoa	1	1
24	18001050	Placa Caracteristicas	1	1
25	15000220	Mando	2	3
26	15001340	Pie Plancha	4	4
27	12300320	Coginete Barbacoa 16x6,5	4	4
28	12050054	Tuerca Ciega M6	4	4
29	16000320	Grifo Plancha	2	3
30	12004220	Tornillo M4x22	4	8
31	27260835	Peto FryTop 35 rectificado	1	1
32	27250310	Bandeja recogemigas	1	1

SECCIÓN B-B

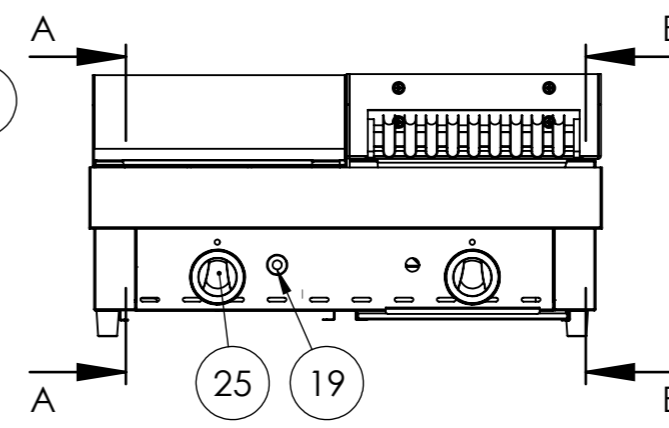
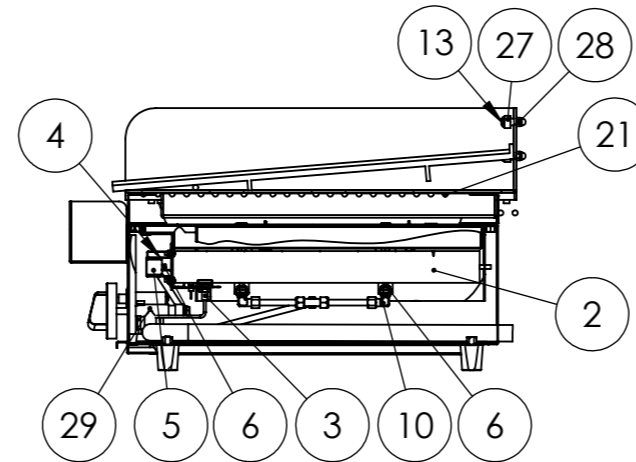

SECCIÓN A-A

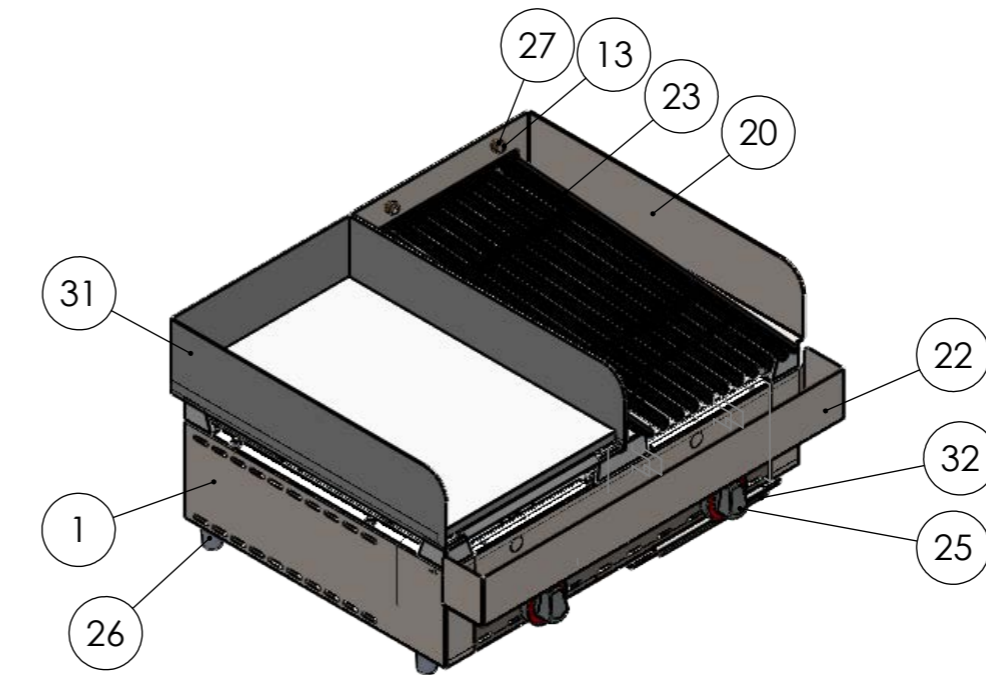
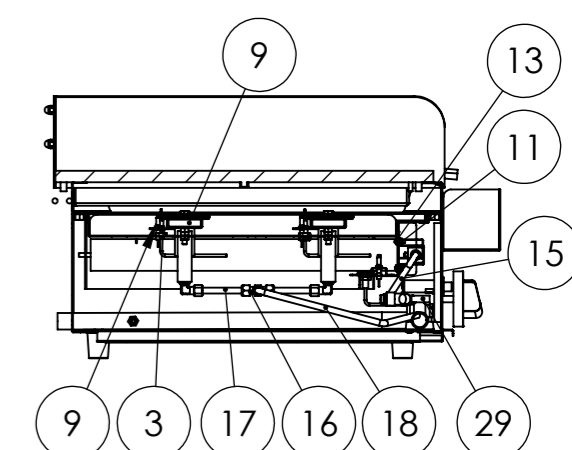

LOSDECORA
 C/ Genoveva Torres Morales, 6 Local 14,
 50006 - Zaragoza. - NIF: B994717116
 Tlf-Fax: 976 255 991

FRYTOP RECTIFICADO + P. Vasca

REVISIÓN					Español	
arilex	FECHA	NOMBRE	FIRMA	MATERIAL:	ACABADO:	
	30/10/2020	CGT				
	VERIF.			CODIGO	N.º DE DIBUJO	
	APROB.					
NOMBRE					A3	
FRYTOP 70/100 FRYGRB						
ESCALA:1:10		PESO:		HOJA 1 DE 1		